



**120 LED DUAL HEAD
SOLAR MOTION LIGHT**
Instruction Manual



Item# 23401

Thank you very much for choosing a Nature Power Product! For future reference, please complete the owner record below:

Model: _____ Purchase Date: _____

Save the receipt and these instructions. It is important that you read the entire manual to become familiar with this product before you begin using it.

This machine is designed for certain applications only. The distributor cannot be responsible for issues arising from modification. We strongly recommend this machine not be modified and/or used for any application other than that for which it was designed. If you have any questions relative to a particular application, DO NOT use the machine until you have first contacted the distributor to determine if it can or should be performed on the product.

For technical questions please call **1-877-548-3387, Earthtech Products, Inc.**

GENERAL SAFETY RULES



WARNING:

Read carefully and understand all **ASSEMBLY AND OPERATION INSTRUCTIONS** before operating. Failure to follow the safety rules and other basic safety precautions may result in serious personal injury.



CAUTION:

Do not allow persons to operate or assemble this solar light until they have read this manual and have developed a thorough understanding of how the solar light works.



WARNING:

The warnings, cautions, and instructions discussed in this instruction manual cannot cover all possible conditions or situations that could occur. It must be understood by the operator that common sense and caution are factors which cannot be built into this product, but must be supplied by the operator.

SAVE THESE INSTRUCTIONS

FEATURES

Your Solar Motion Light is the perfect system for following:

- Entrance
- Garage
- Porch
- Eaves
- Emergency

PARTS LIST

Part	Description
1	Lamp
2	Solar Panel (16 ft. wire)
3	Screws & Anchors
4	Mounting Bracket
5	Manual

Battery included, not a part

USE AND CARE

- **Do not modify the solar light in any way.** Unauthorized modification may impair the function and/or safety and could affect the life of the equipment. There are specific applications for which the **solar light** was designed.
- **Always check for damaged or worn out parts before using the solar light.** Broken parts will affect the solar light operation. Replace or repair damaged or worn parts immediately.
- **Store idle solar light.** When solar light is not in use, store it in a secure place out of the reach of children. Inspect it for good working condition prior to storage and before re-use.

ASSEMBLY

1. *Lamp Unit Installation*

- Mounting your light requires a screwdriver, pencil and (in some circumstances) a power drill.
- Place the mounting bracket on the surface you wish to mount to.
- Mark with a pencil the position of the mounting bracket screw holes (3). This will enable you to pre-drill your screw holes.
- Once the mounting bracket is installed, ensuring all screws are tight, you are ready to position your 120 LED Ultra Bright Motion Light.
- Carefully route the wire from the solar panel to the lamp and plug it into the power socket.
- Adjust the motion sensor to your desired position. Your 120 LED Ultra Bright Motion Light is now installed and ready to charge.

Note: Lamp unit should be mounted 6.5 ~ 9.8ft from the ground to ensure motion detection is optimized.

2. *Solar Panel Wall or Roof Mounted Installation*

- Choose an area that receives the maximum amount of sunlight possible.
- Use the holes located on the solar panel mounting bracket to mark the mounting surface for installation.
- Set the bracket on the surface you have chosen and secure it in place with the 3 screws and anchors provided.
- Adjust the angle of the Solar Panel to ensure it receives optimum sunlight.

Note: The Solar Panel is equipped with a 16 ft. wire. The maximum distance between the lamp unit and solar panel can be 16 ft.

ASSEMBLY DIAGRAM

Part	Description	Part	Description
1	Lamp	9	Power Socket
2	Solar Panel (16 ft. wire)	10	Solar Panel Mounting Bracket
3	Screws & Anchors	11	Battery Housing
4	120 LED's	12	Coupling Shaft
5	Mounting Bracket	13	LUX Adjusting Knob
6	Motion Detector Head	14	SENS Adjusting Knob
7	Arm	15	TIME Adjusting Knob
8	ON/OFF/AUTO Switch	16	NI-MH Battery Pack (not shown)

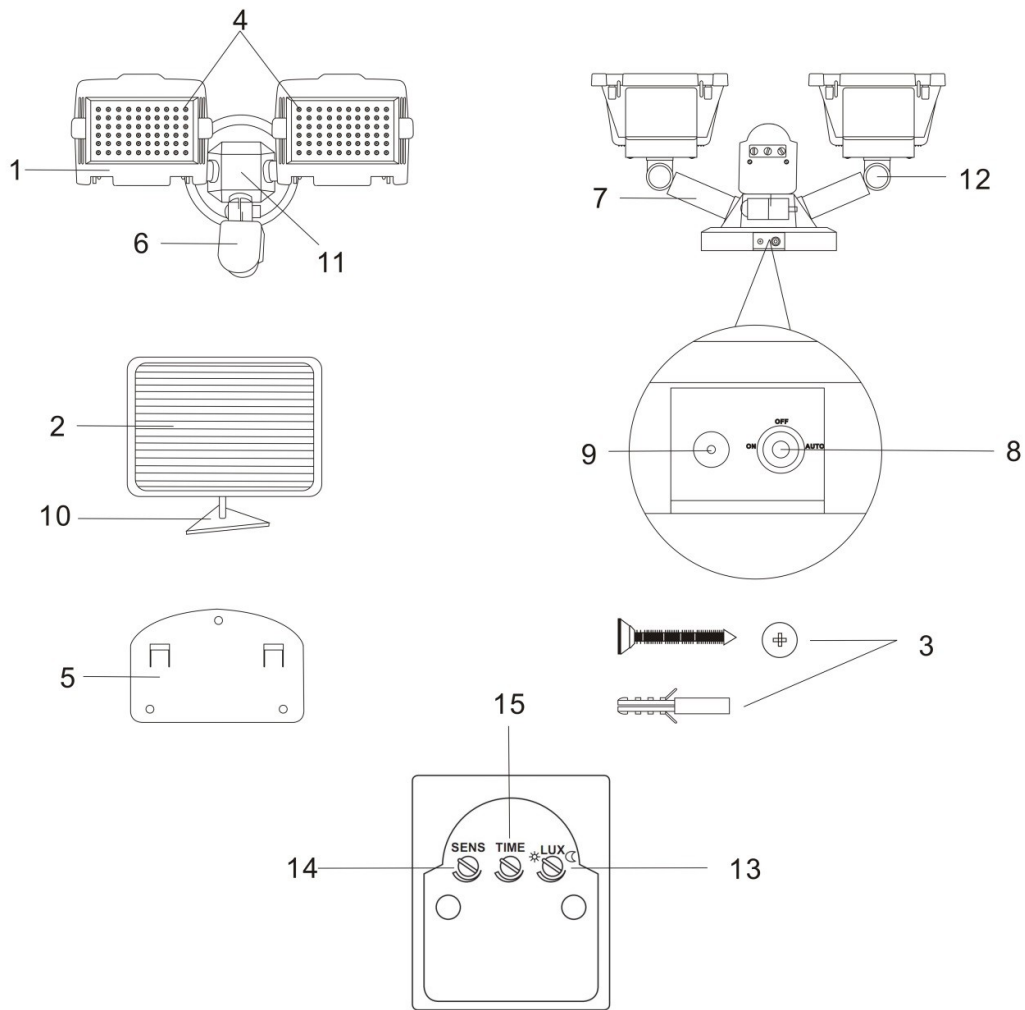

OPERATION

- Before the Solar Motion Light can operate to its full capacity, the Solar Panel needs to be in sunlight for 3 days to fully charge the included battery. Charging should be done with the unit in the "OFF" position.
- Located at the bottom of the Battery Housing (11) there is a switch with three positions:
 - Turn the switch to "AUTO" position, the light will turn on automatically at night when motion is detected by the Motion Detector Head (6).
 - Turn the switch to "ON" position, the light can be used as a standard light for constant illumination.

- Turn the switch to “OFF” position, the light will remain off and will not detect any movement.

3. The lamp heads and arms are adjustable:

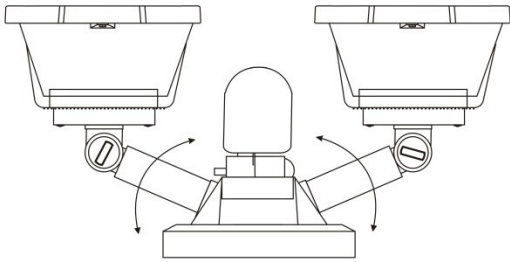

- Both arms can be rotated 180° front and back.

- Coupling Shafts can be rotated 180° horizontally.

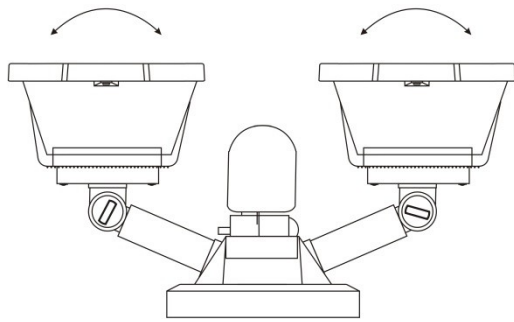

- Both lamp heads can be rotated 180° left and right. Adjust these parts and joints to reach optimum angle and range of illumination.

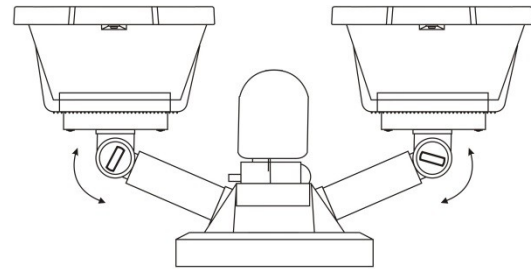

4. The

Motion Detector Head is adjustable:

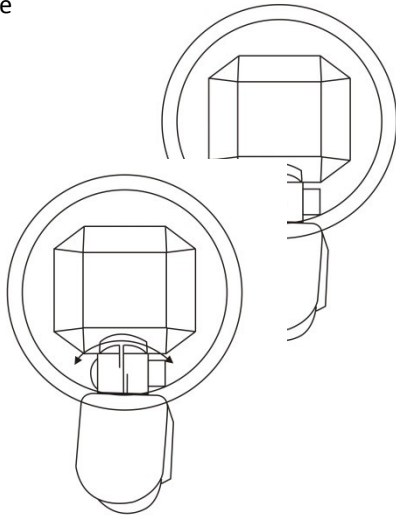

- Coupling shaft can be rotated 180° up and down.

- The joint connecting to the Battery Housing can be rotated 180° left and right. Adjust these joints to reach optimum angle and range of detection.



NOTE: Light will function when the photo-sensor senses minimal light.

HOW TO USE CONTROL DIALS

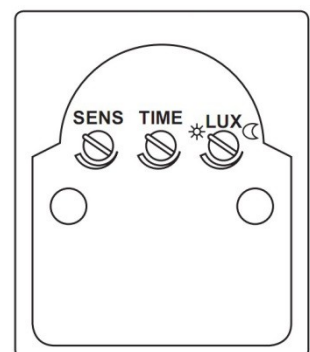
The Solar Motion Light has 3 different control dials which control the light’s duration, sensitivity to light and sensitivity to motion.



LUX (LIGHT LEVEL)

1. The LUX Adjusting dial (13) tells the sensor the level of darkness that must be reached before the light turns on.
2. If set to the maximum  level, the light will go on in daylight.
3. If set to the minimum setting  the sensor will only trigger the light to turn on at dusk or when it is dark out. This is the ideal position for general usage.

TIME

1. The TIME Adjusting dial (15) sets the duration of illumination time.
2. The TIME is adjustable from 8 seconds to 2 minutes. Rotating the dial clockwise will increase the illumination time.

SENS (SENSITIVITY)

This determines the range of motion detection:

1. Mid position - Normal setting.
2. Maximum position - Maximum range.

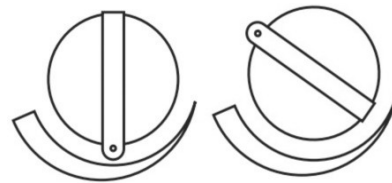

LOCATION OF SOLAR PANEL

For best results, please locate your solar panel in a position where it can absorb direct sunlight on the solar panel, and generally free from cover and shade.



TROUBLESHOOTING

If the Solar Motion Light does not illuminate when movement in front of the sensor is obvious, please observe the following:

- Ensure the solar panel is in a location where it will receive maximum sunlight during daytime hours.
- Ensure the lamp head is away from other light sources. Other light sources at night will prevent the unit from turning on.
- Ensure switch is set to "AUTO" position.
- Check batteries are installed correctly.
- Allow the solar panel to charge the batteries in direct sunlight for 3 days with the switch in the "OFF" position.
- Replace Batteries.

Note: Rechargeable batteries may last up to 600 charges. For best performance replace batteries every 12 months.

MAINTENANCE

Maintain your solar light. It is recommended that the general condition of any solar light be examined before it is used. Clean the solar module with a damp towel to ensure optimum performance of the solar light. Do not use any type of solvent for cleaning and be careful not to put too much pressure on the module while cleaning.

BATTERY REPLACEMENT

1. The Battery Pack is located in the Battery Housing (11).
2. Turn the Switch (8) to the "OFF" position. Remove the four screws from the Battery Housing (11). Separate the Battery Pack connector. Remove old Battery Pack. Replace only with identical rechargeable Battery Pack (16).
3. Check correct polarity of battery replacement.
4. Replace the cover of the Battery Housing (11). Secure it with the four screws.

LIMITED WARRANTY

Nature Power warrants our products to the original purchaser that this product is free from defects in materials and workmanship for the period of one year from date of purchase.

Dated Proof of Purchase is required.

For inquiries or more information, please contact:

Earthtech Products, Inc.
10A Merrick Avenue
Merrick, NY 11566
Tel: 1-877-548-3387
Fax: 1-877-548-3387
<http://www.earthtechproducts.com/>