

DC COMPRESSOR FRIDGE-FREEZER

MODEL: Grape Glacier 1.1

INSTRUCTION MANUAL

ENGLISH

Congratulations on the purchase of this quality Refrigerator-Freezer. We the manufacturer trust that you will enjoy many years of trouble free use. Please read the instructions carefully before using your Refrigerator-Freezer. This book will provide you with information on how to operate and care for your Refrigerator-Freezer in order to gain the maximum benefit from it.

The appliance must be earthed and connected to a suitable 120volt or 12 volt socket. The manufacturer and the seller do not accept responsibility for any damage due to incorrect electrical installation.

©Copyright 2012, Grape Solar, Inc. All Rights Reserved

TEST-RUN

DC input condition, the voltage range required is DC10.9V~28V, if the power is not stable, the unit will not run. The unit will restart when the voltage is normal. Cut out 10.4VDC, cut in 11.8VDC.

AC input condition; the voltage range required is 120V.

Do not pull the appliance by power cord.

Connect power, set the digital thermostat to -18□ and check the indicators, 30 minutes later, open the door and check the inside surface. If the inside surface is cold, your appliance is working.

Operation with AC120V/60Hz

Connect the appliance to a AC120V power source using the removable AC cable supplied with the appliance.

In the Temperature window the temperature last set will flash for 5 seconds and then automatically change to display the temperature inside the cabinet.

Press the “Up” or “Down” keys to set the temperature you require.

The set temperature will flash for 5 seconds and then automatically change to display the temperature inside the cabinet.

To turn off the appliance, remove the plug from socket.

Operation with DC12V/DC24V

Connect the “DC cable supplied with the appliance to a suitable DC socket outlet .A 120 watt dc socket outlet is recommended, DO NOT USE THE CIGARETTE LIGHTER SOCKET OUTLET TO RUN THIS FREEZER. The appliance will automatically identify and apply DC12V or DC24V.

In the Temperature window the digital temperature last set will flash for 5 seconds and then automatically change to display the temperature inside the cabinet.

Press the “Up” or “Down” keystrokes to set the temperature you required.

The set temperature will flash for 5 seconds and then automatically change to display the temperature inside the cabinet.

To turn off the appliance, remove the DC plug from the DC socket.

DEFROSTING AND DE-ODORIZING

When the ice layer on the inner cabinet sides is over 5mm, defrosting operation should be performed to improve the refrigerating efficiency.

Disconnect power, remove all items and clean unit. After defrosting, clean with a soft rag and switch the appliance on.

Note: Never remove ice with sharp objects.

Place charcoal in the appliance to remove any bad odors.

MAINTENANCE AND REGULAR CLEANING

Always disconnect the power supply before cleaning. Clean the inside of the cabinet whenever necessary using a warm solution of water and bicarbonate of soda(1 tablespoon to every 2 liters of water) dry with a soft cloth



Dirt from the condenser should be cleaned by a qualified technician when necessary.

NOT A MALFUNCTION

It is normal to hear gurgling sounds caused by the flow of refrigerant when each cooling cycle ends. The surface temperature of the compressor can reach 70-90° when running.

The noise emitted by the cooling fan on the condenser is a normal condition.

MAIN TECHNICAL PARAMETER

MODEL: DC-35P	SERIAL: NO.
DC COMPRESSOR FRIDGE-FREEZER	NET VOLUME: 35L REFRIGERANT: R134A / 35 GRAMS INSULATION: CYCLOPENTANE
POWER INPUT: 55W AC , 37W DC CURRENT: 0.25AMPS AC, 3.08AMPS/1.54AMPS DC INPUT VOLTAGE: 220-240V/60HZ AC, 12/24V DC CLASS: T	 
MADE IN CHINA	
READ MANUFACTURER'S INSTRUCTIONS BEFORE USE THIS APPLIANCE MUST BE INSTALLED ACCORDING TO THE MANUFACTURER'S INSTRUCTIONS TO BE USED ONLY IN WELL-VENTILATED AREA	

SAFTY:

A separate earthed 15A socket outlet should be used on 120V AC and at least a 120W DC socket on 12V DC.

In the event of any malfunction of your freezer, please contact the nearest service agent.

CIRCUIT DIAGRAM

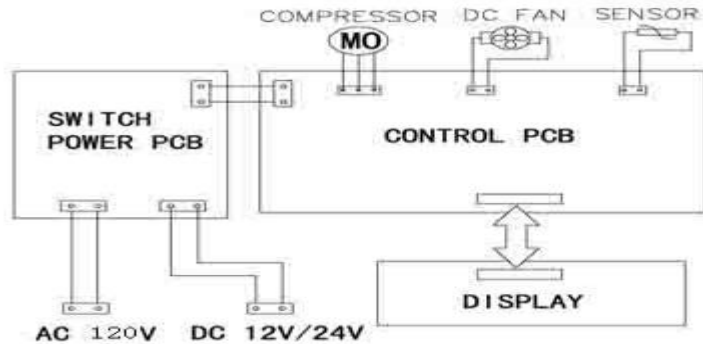

TROUBLESHOOTING

problem	Cause	Remedy
The compressor runs for 1~5 minutes and stops	The voltage is not in the normal range	Switch off power and restart when power is normal
The compressor runs but inner liner does not get cold	The refrigerant has leaked	Contact your local dealer
	The system is blocked	
The inner liner is very cold and the compressor runs continuously.	The door is being opened and closed too frequently	The door should be opened as little as possible
	The condenser is not well-ventilated. The controller is faulty	Select a well-ventilated place
The compressor does not run	"+" and "-" are switched.	Rectify
	The controller is faulty (the power indicator is not on)	Contact your local dealer
	The thermostat is set too high; the ambient temperature is too low.	Use as a freezer
The freezer is noisy	The freezer is not placed properly.	Make the freezer level
	Some parts have come loose.	Contact your local dealer
	The pipes are touching.	Contact your local dealer

MOVEMENT AND INSTALLATION

When moving the freezer, the angle between the cabinet and the ground should not be less than 45° in order to protect the compressor and refrigerating system.

Position the freezer in a dry and well-ventilated place. Keep the freezer away from direct sunlight, heaters and corrosive gases.

The normal operation of the freezer depends on the heat radiation of the condenser. For the initial use, the packing foam must be taken off and at least 150mm space must be left around the freezer.